

COUPLED ANALYSIS OF NON-CONTACTING PROFILED FINGER SEALS TAKING INTO ACCOUNT FRICTION EFFECTS

Kaibing Du¹, Alexander O. Pugachev², Yongjian Li¹, and Yuming Wang¹

¹ State Key Laboratory of Tribology, Tsinghua University, 100084 Beijing, China
E-mail: dkb11@mails.tsinghua.edu.cn

² Institute of Energy Systems, Technische Universitaet Muenchen, 85748 Garching, Germany
E-mail: pugachev@tum.de

Abstract: A computational model for coupled fluid-structure interaction analysis taking into account friction contacts is developed to study lifting capability and leakage performance of non-contacting finger seals. A cyclic finger seal segment consisting of one low-pressure finger, halves of two high-pressure fingers, front and back plates is considered. Compressible air flow in the finger seal is modeled using a computational fluid dynamics approach. A non-linear three-dimensional solid model takes into account friction contacts between the fingers and seal plates.

Keywords: *fluid-structure interaction, computational fluid dynamics, friction contact, leakage*

1 Introduction

Non-contacting finger seal technology represents a promising advanced sealing concept with compliant elements for gas turbine engines. Finger seals offer leakage reduction capability comparable to brush seals, but are less expensive in manufacturing (Braun et al., 2003; Proctor and Delgado, 2008). Self-acting lift pads of the low-pressure fingers maintain non-contacting operation throughout the operating pressure and speed ranges by providing a small radial clearance even in case of rotor excursion. Therefore, it is very important to adequately account for compliance of fingers when predicting sealing performance of finger seals.

Braun et al. (Braun et al., 2003) published the first study on the coupled fluid-solid analysis of a non-contacting finger seal with padded low-pressure fingers. Low-pressure and high-pressure fingers were treated in a finger seal segment model as a single piece. A triangular-shaped simulated pressure loading was applied in the structural model to study the deformation of fingers. The friction between the low-pressure finger and back plate was described by a distributed traction force.

In a subsequent work, Marie (Marie, 2006) presented coupled analysis for non-contacting finger seals to obtain equivalent dynamic coefficients. Dynamic simulations were performed with a two-degree-of-freedom mass-spring-damper model of finger seals with different wedge pad designs. Recently, many other works on fluid-structure interaction analysis of non-contacting finger seals were published, e.g. (Temis et al., 2013; Zhang et al., 2013).

This work describes a new non-linear coupled fluid-solid model to study the nature of non-contacting finger seal deformation and leakage performance. The model considers the contacting friction forces between the low-pressure and high-pressure fingers, as well between fingers and front and back plates. Simulations are performed for different pad designs.

2 Non-contacting finger seals

The geometry of the modeled finger seal segment is shown in figure 1. The model includes parts of the front plate (FP) and the back plate (BP), one low-pressure padded finger (LP), and two halves of the high-pressure unpadded fingers (HP). The shaft diameter is 73 mm. The reference pressure drop is 0.2 MPa. The shaft rotational speed is 20 000 rpm. Full sealing configuration consists of 81 low-pressure and high-pressure fingers. The circumferential slots between the fingers is 0.4 mm.

Different profiles of the low-pressure finger pads are considered: (a) the clearance between the plain LP finger pad and rotor surface is held constant at 20 μm ; (b) the LP finger pad has an axial convergent wedge profile with the maximum clearance of 20 μm and the minimum clearance of 2 μm ; (c) the LP finger pad has a circumferential step profile (Rayleigh step): in shaft rotating direction, the clearance between the first half of the LP pad and the rotor surface is 20 μm , the other part has the radial clearance of 2 μm .

3 Modeling approach

The coupled simulation of the finger seal behavior is organized using two separate models for the aerodynamic and structural analyses. Structural grids for both models are generated in ANSYS ICEM CFD.

A SST-RANS approach in ANSYS CFX is used to model compressible gas flow in the finger seal channel. The computational domain of the CFD model represents the finger seal segment shown in figure 1 with additional

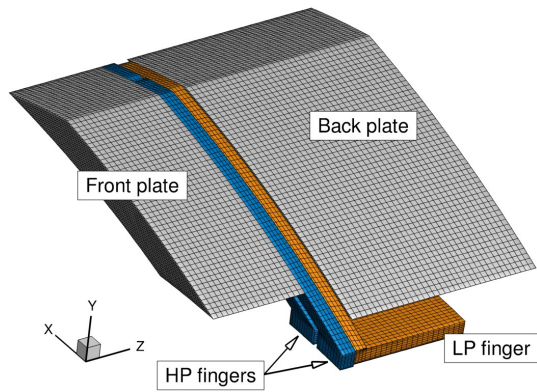

Figure 1: Solid part of the finger seal segment model.

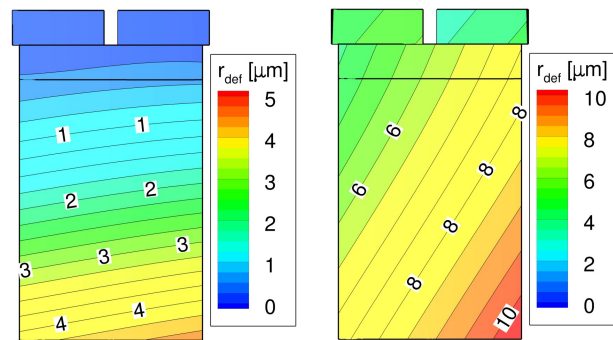

Figure 2: Pad deformations for the cases 1 (left) and 2 (right).

upstream and downstream cavities, as well as rotor surface. A pressure drop is defined between the inlet and outlet boundaries. Periodic boundary conditions are set at the cutting faces.

The structural model of the finger seal segment is built in ANSYS Mechanical using surface-to-surface contact capability to model interaction between fingers and plates. Pressure loads are directly imported from the CFD simulation. Deformation of pads is approximated and transferred to the moving mesh algorithm using CFX expression language. Coupled CFD-FEA iterations are performed in a semi-manual manner.

Depending on the assumptions and complexity of models, the following approaches to study non-contacting finger seals are considered: two contact pairs with friction ('LP-BP' and 'HP-FP', case 1); three contact pairs ('LP-BP', 'HP-FP', and 'HP-LP', case 2).

4 Analysis

The non-linear coupled simulation of non-contacting finger seals takes considerably more calculating time as compared to the fluid-structure interaction simulations without contacts or other, more simplified approaches. Also, higher number of coupled iterations between CFD and FEA is needed when considering non-linear structural model. However, the developed approach provides useful information on the contact status and contact pressure in the components of the finger seal. The results show that the maximum contacting pressure occurs in the contact pair 'HP-LP' and at the inner diameter of the back plate in the contact pair 'LP-BP'.

As expected, the pad profile has a significant effect of the lifting capability of the low-pressure fingers. The finger seal with the Rayleigh step demonstrated the lowest mass flow rates among the considered configurations. The profiled pads provide an increased gas film stiffness and can be designed in a way to ensure non-contacting stable operation during rotor excursions.

Taking into account contact interaction with friction also considerably changes the predictions of finger deformation and leakage performance of the finger seals (see results for the configurations with Rayleigh step shown in figure 2). Therefore, these effects must be considered in the finger seal performance analysis. The presented model also enables analysis of other parameters (e.g. friction coefficient) to study their influence on simulation results.

Acknowledgements

Kaibing Du would like to acknowledge support of the Tsinghua Visiting Doctoral Students Foundation Program.

References

- M. J. Braun, H. M. Pierson, and V. V. Kudriavtsev. Finger seal solid modeling design and some solid/fluid interaction considerations. *Tribology Transactions*, 46:566–575, 2003.
- H. Marie. Dynamic simulation of finger seal-rotor interaction using variable dynamic coefficients. In *42nd AIAA/ASME/SAE/ASEE Joint Propulsion Conference & Exhibit*. Sacramento, CA, 2006. AIAA 2006-4931.
- M. Proctor and I. Delgado. Preliminary test results of a non-contacting finger seal on a herringbone-grooved rotor. In *44th AIAA/ASME/SAE/ASEE Joint Propulsion Conference & Exhibit*. Hartford, CT, 2008. AIAA2008-4506.
- J. Temis, A. Selivanov, and I. Dzeva. Finger seal design based on fluid-solid interaction model. In *ASME Turbo Expo*. San Antonio, Texas, USA, 2013. GT2013-95701.
- H. Zhang, Q. Zheng, G. Yue, and Q. Deng. Unsteady numerical analysis of a whole ring of finger seal with grooves on finger pads. In *ASME Turbo Expo*. San Antonio, Texas, USA, 2013. GT2013-94514.